

1



**Verwendung:**

Zur Aufnahme von Walzen-, Walzenstirnfräsern oder Messerköpfen mit Längs- oder Quernut.

**Application:**

For mounting milling cutters with transverse or longitudinal groove.

**Application:**

Destiné à recevoir les fraise cylindriques, les fraises frontales cylindriques ou les têtes de fraisage avec rainure longitudinale et transversale.

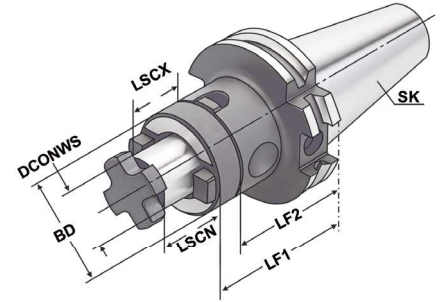

ISO 7388-1	Form AD/AF (AD/B)	$\leq 5\mu\text{m}$	G6.3 15.000 min <sup>-1</sup>	RFID Chip	DIN 6358	h6
------------	-------------------	---------------------	-------------------------------	-----------	----------	----

Bestell-Nr. Order no. Référence	SK	DCONWS	TDCON	LF1	LF2	LSCN	LSCX	BD
302.10.16*	SK 30	16	h6	50	40	17	27	32
302.10.22*	SK 30	22	h6	50	38	19	31	40
302.10.27*	SK 30	27	h6	55	43	21	33	48
302.10.32*	SK 30	32	h6	60	46	24	38	58
<hr/>								
403.10.16	SK 40	16	h6	55	45	17	27	32
403.10.22	SK 40	22	h6	55	43	19	31	40
403.10.27	SK 40	27	h6	55	43	21	33	48
403.10.32	SK 40	32	h6	60	46	24	38	58
403.10.40	SK 40	40	h6	60	46	27	41	70
<hr/>								
403.10.16.1	SK 40	16	h6	100	90	17	27	32
403.10.22.1	SK 40	22	h6	100	88	19	31	40
403.10.27.1	SK 40	27	h6	100	88	21	33	48
403.10.32.1	SK 40	32	h6	100	86	24	38	58
403.10.40.1	SK 40	40	h6	100	86	27	41	70
<hr/>								
403.10.16.2	SK 40	16	h6	160	150	17	27	32
403.10.22.2	SK 40	22	h6	160	148	19	31	40
403.10.27.2	SK 40	27	h6	160	148	21	33	48
403.10.32.2	SK 40	32	h6	160	146	24	38	58
403.10.40.2	SK 40	40	h6	160	146	27	41	70

\* Form AD  
\* Form AD  
\* Forme AD

**Lieferumfang:** Mit Fräseranzugsschraube, Mitnehmerring und Passfeder  
**Delivery:** With retaining screw, driving ring and feather key  
**Livraison:** Avec vis de serrage, bague d'entraînement et clavette





**Verwendung:**  
Zur Aufnahme von Walzen-, Walzenstirnfräsern oder Messerköpfen mit Längs- oder Quernut.

**Application:**  
For mounting milling cutters with transverse or longitudinal groove.

**Application:**  
Destiné à recevoir les fraise cylindriques, les fraises frontales cylindriques ou les têtes de fraisage avec rainure longitudinale et transversale.

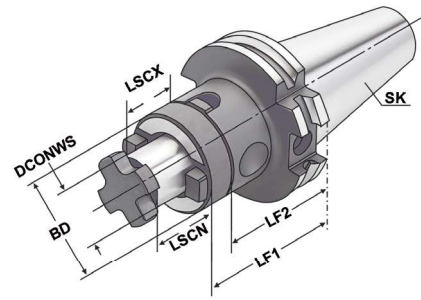

ISO 7388-1    Form AD/AF (AD/B)     $\leq 5\mu\text{m}$     G6.3 15.000 min<sup>-1</sup>    RFID Chip    DIN 6358    h6

Bestell-Nr. Order no. Référence	SK	DCONWS	TDCON	LF1	LF2	LSCN	LSCX	BD
503.10.16	SK 50	16	h6	55	45	17	27	32
503.10.22	SK 50	22	h6	55	43	19	31	40
503.10.27	SK 50	27	h6	55	43	21	33	48
503.10.32	SK 50	32	h6	55	41	24	38	58
503.10.40	SK 50	40	h6	55	41	27	41	70
503.10.16.1	SK 50	16	h6	100	90	17	27	32
503.10.22.1	SK 50	22	h6	100	88	19	31	40
503.10.27.1	SK 50	27	h6	100	88	21	33	48
503.10.32.1	SK 50	32	h6	100	86	24	38	58
503.10.40.1	SK 50	40	h6	100	86	27	41	70
503.10.16.2	SK 50	16	h6	160	150	17	27	32
503.10.22.2	SK 50	22	h6	160	148	19	31	40
503.10.27.2	SK 50	27	h6	160	148	21	33	48
503.10.32.2	SK 50	32	h6	160	146	24	38	58
503.10.40.2	SK 50	40	h6	160	146	27	41	70

**Lieferumfang:** Mit Fräseranzugsschraube, Mitnehmerring und Passfeder  
**Delivery:** With retaining screw, driving ring and feather key  
**Livraison:** Avec vis de serrage, bague d'entraînement et clavette



**Nachträgliches Erodieren von 2 Kühlkanalbohrungen**  
*Supplementary eroding of 2 cooling channels*  
Erodage complémentaire de 2 trous de canaux de refroidissement

Bestell-Nr.  
Order no.  
Référence

U.KKB

